

## CPA-PPCD04



Proportional  
valves

Directional  
valves

Smart  
products

Special  
designs

### Product classification

Name	Max volume flow @ 6 bar dp	
PPCD03	1,25 l/min	Direct controlled
<b>PPCD04</b>	<b>2,5 - 5 l/min</b>	
PPCD05	10 l/min	
PPCD06	15 l/min	
PPCD08	20 l/min	
PPCD09	30 l/min	Pilot operated
PPCP09	35 l/min	
PPCP13	72 l/min	

### Benefits

- ≡ **Durability:** 2 mm connector wall
- ≡ **Optimized design for smaller applications:** only 26 mm wide
- ≡ **Flexible mounting:** rotatable flange with just one screw – saves time
- ≡ **Space-saving:** 60° angled connector for optimized wire routing
- ≡ **Faster response:** 25% shorter response time
- ≡ **Waterproof:** IP6K6 thanks to overmolded solenoid



### Hydraulic Data

Max pressure pump	$P_p = 50$ bar
Max pressure tank	$P_T = 10$ bar
Max pressure work	$P_A = 16 \pm 3, 20 \pm 3$ or $25 \pm 3$ bar (28 bar on request)
Hysteresis	Typical 0,5 - 1,2 bar (depending on control signal)
Contamination level	Max. 20/18/15 According to ISO 4406
Fluid	Mineral Oil According to DIN 51524
Temperature range fluid	-30 °C to +90 °C
Leakage (internal)*	< 0,06 l/min (de-energized) < 0,25 l/min (energized)
Filterscreen size	125 $\mu$ m (P-Port)

### Electrical Data

Voltage	12 V	24 V
Max current	1500 mA	750 mA
Resistance	3,76 $\Omega \pm 5\%$	15,88 $\Omega \pm 5\%$
Type of control (recommended)	Dither 100 Hz 300 mA PTP	Dither 100 Hz 150 mA PTP
Connector	Deutsch Connector DT04-2P	
Protection class	Up to IP6K6 / IPX7	
Switching time	$t_{on} < 40$ ms ( $p_A = 0\%$ to $90\%$ ) $t_{off} < 40$ ms ( $p_A = 100\%$ to $10\%$ )	

\* The reported data are measured @ $P_p = 35$  bar (16, 20 and 25 bar version), oil viscosity of 32 cSt

### Current vs. Pressure (Average characteristic)

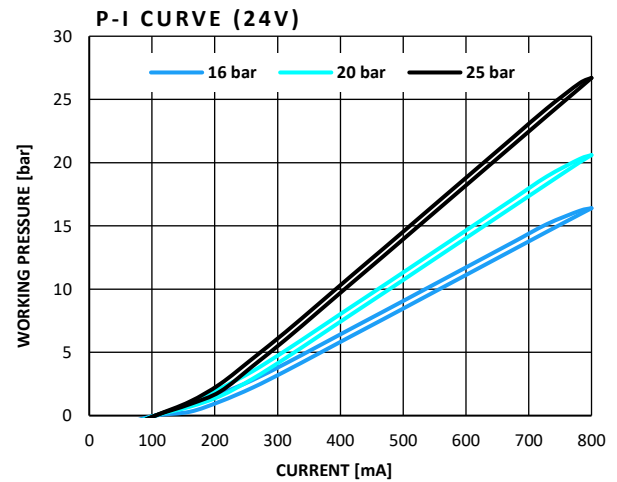
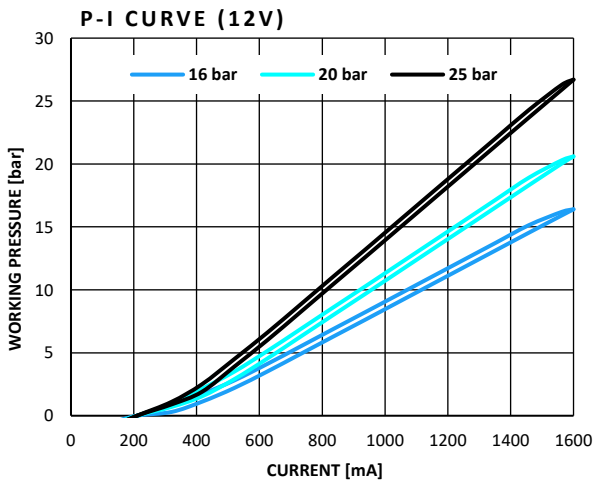

### Flow characteristics (Average characteristic)

**PRESSURE DROP PUMP TO CONTROL PORT (P→A)**  
Valve only

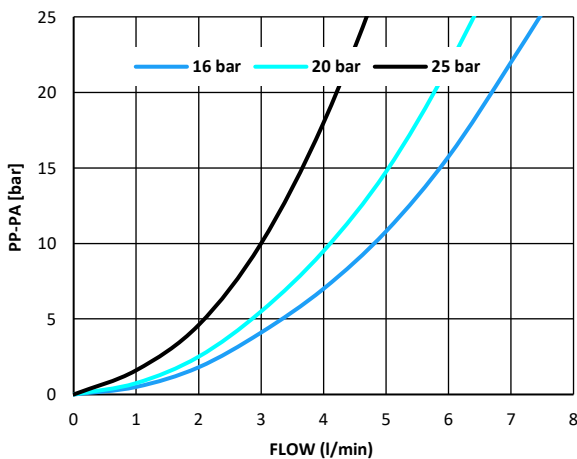

**PRESSURE DROP CONTROL PORT TO TANK (A→T)**  
Valve only

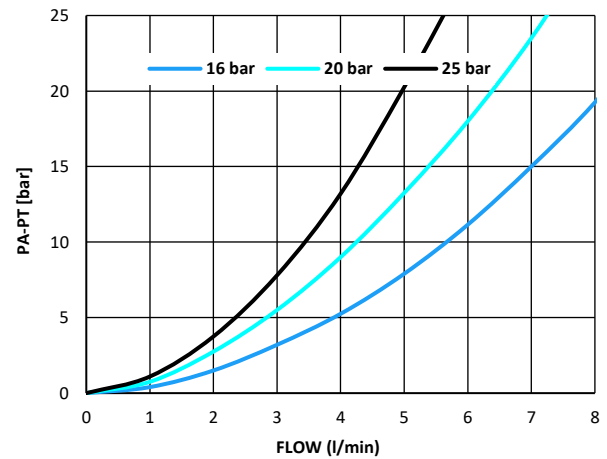



### Hydraulic schematic

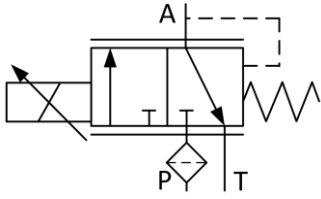

### Additional data

<b>Weight</b>	150 g
<b>Mounting position</b>	Any
<b>MTTF<sub>a</sub>-value</b>	150 years According to ISO 13849-2 C1, C2
<b>Reference</b>	Valve specification according to Thomas LHP 100

### Dimensions with Deutsch Connector [mm]

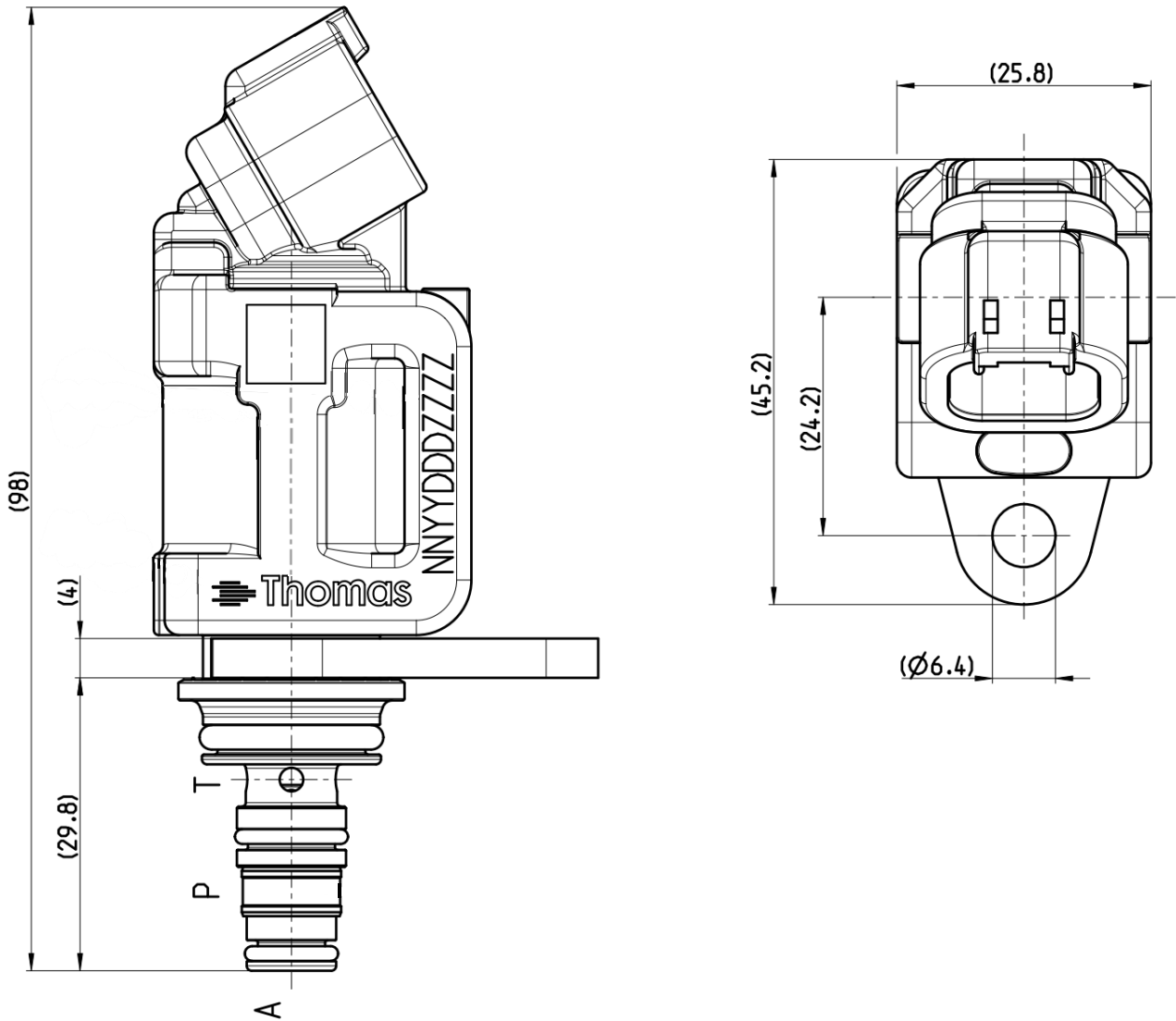



**Cavity Dimensions (All dimensions in mm)**

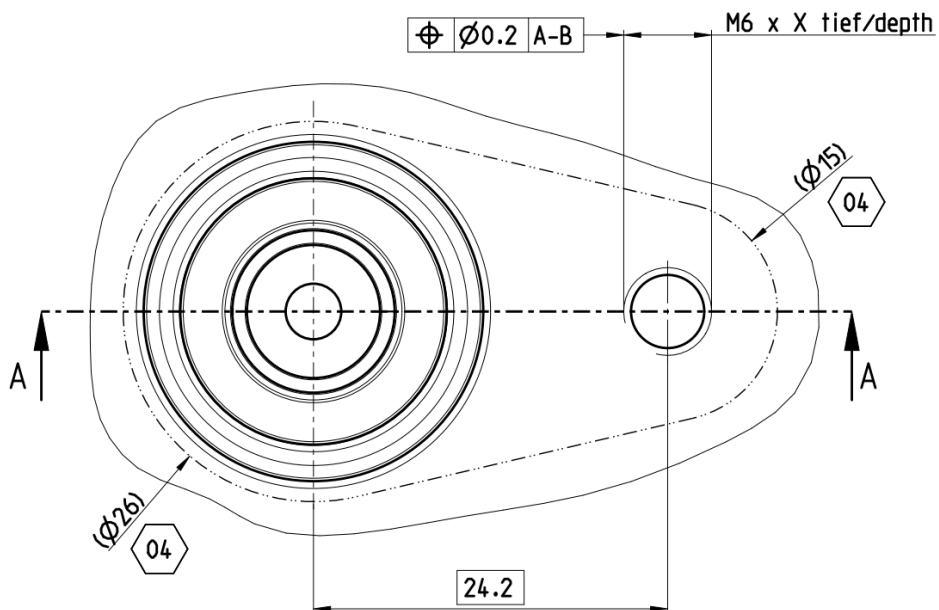
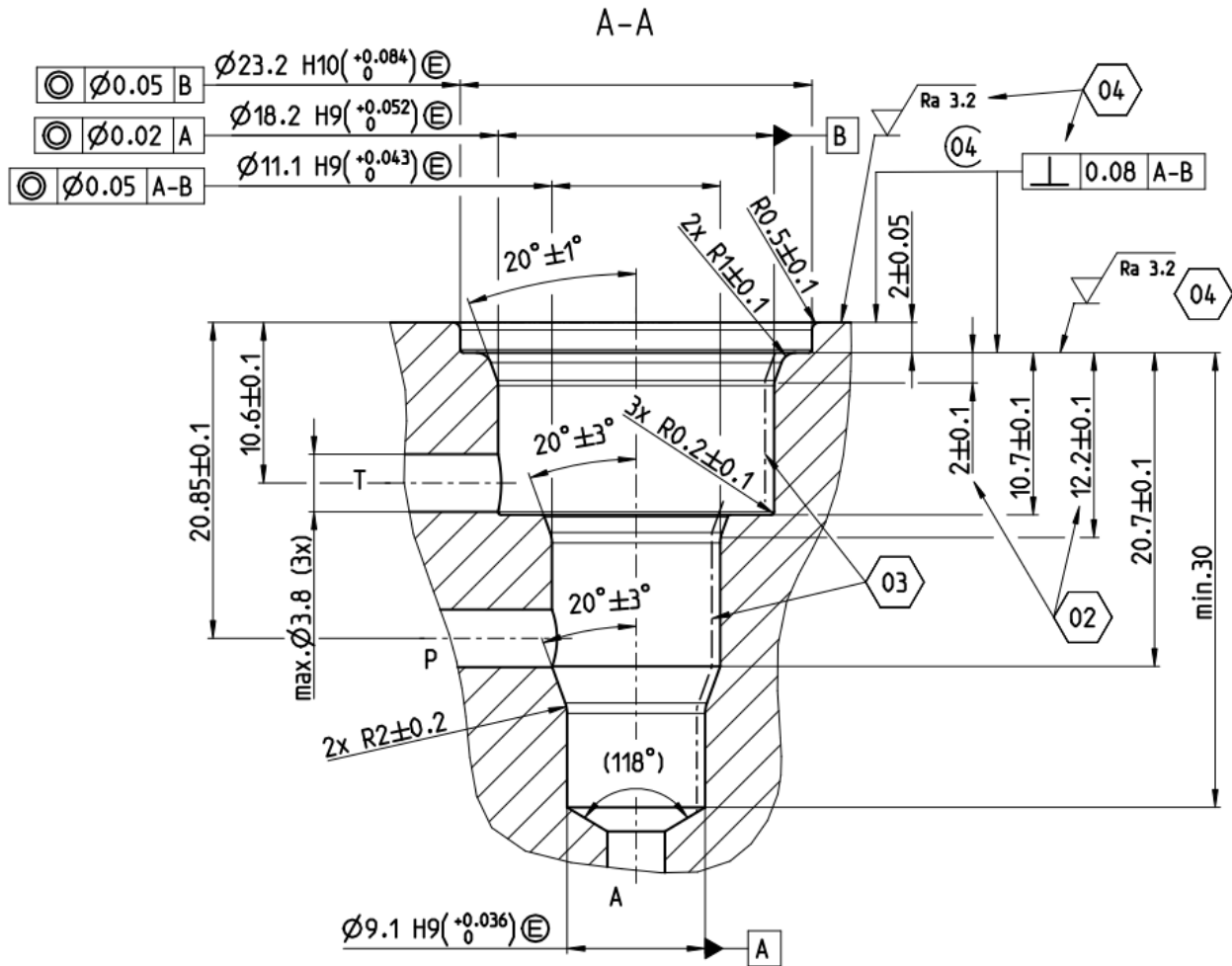



## Model Code

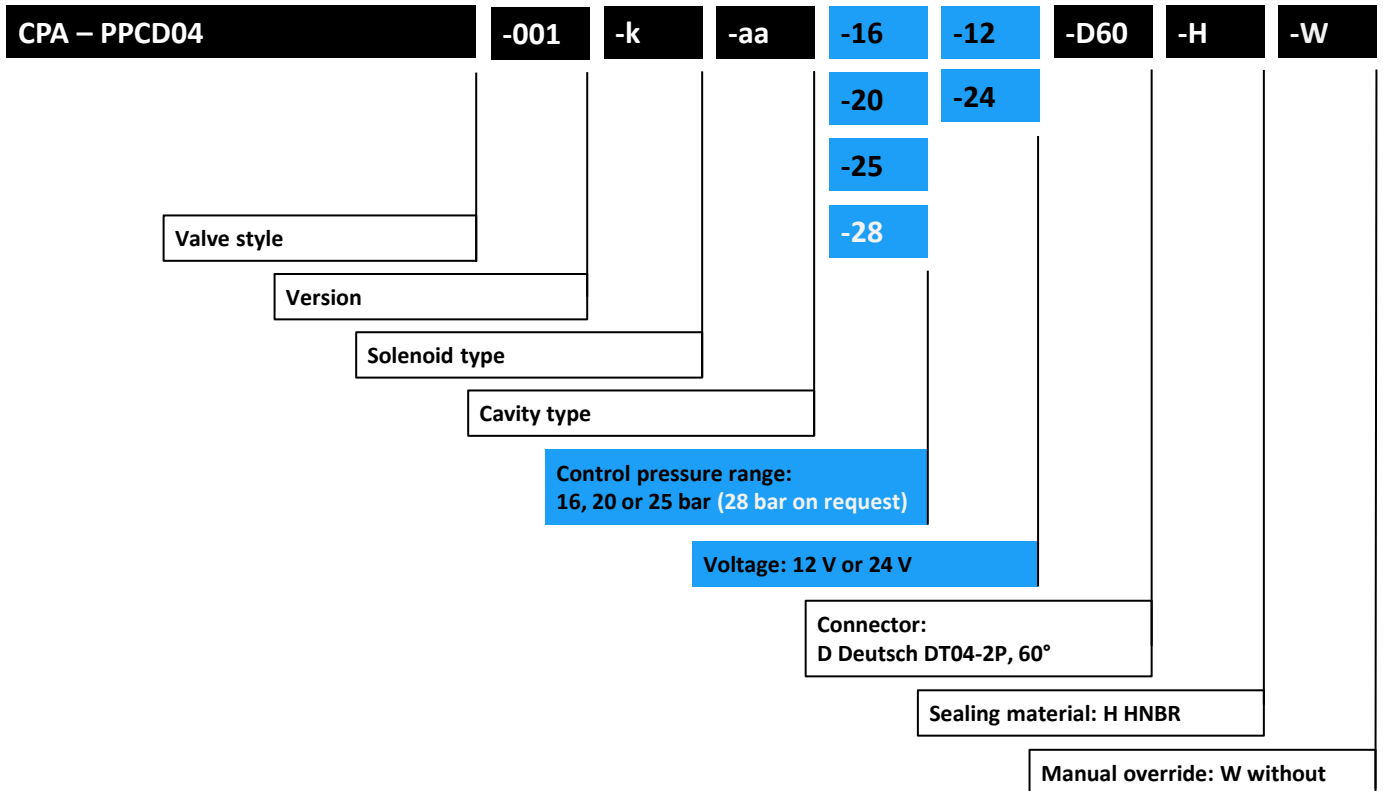

- Defined by Thomas
- Customers choice

### DISCLAIMER



The presented information is based on current knowledge and provides only non-binding information to the customer. Any liability in connection with this information is excluded. It is the responsibility of the customer to determine the suitability and appropriateness of the product for his intended purpose. We reserve the right to change the product with regard to technical progress and new developments.

### CONTACT DETAILS



#### Thomas GmbH

- Innomotion Park 3  
57562 Herdorf, Germany
- Tel. +49 2744 929-220
- [sales@thomas-magnete.com](mailto:sales@thomas-magnete.com)
- [TECsupport@thomas-magnete.com](mailto:TECsupport@thomas-magnete.com)
- [www.thomas-group.com](http://www.thomas-group.com)